

GD ULTRA

Compact grease degrader

GD ULTRA is a cost-effective and compact grease degrader designed to treat drains in food preparation environments. Small and easy to install, the system ensures the smooth running of waste water drainage systems by reducing blockages in waste traps and pipes which are usually caused by the build-up of solid food waste. The solution also prevents unpleasant odours and unhygienic conditions which invariably need chemical or mechanical treatment.

At the core of the system is an ultra concentrated natural consumable based on specially selected bacteria which when dispensed into the drainage system regularly, digest food derived oils, fats and greases and other organic matter. The consumable produces a continuous and renewable supply of highly active enzymes and bacteria, which enables it to continue working between doses.

Finishes available

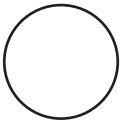

Classic White



Benefits

Ease of Service

- > Compact system is easy to deliver and install
- > Error-proof easy load consumable refill
- > Unit requires minimal warehouse storage space

Cost control & Efficiency

- > Ultra concentrated consumable aids efficiency and cost control
- > Consumable continues working between doses and provides longer lasting protection than biological or caustic products
- > Unit uses two D cell batteries, no mains electricity or large batteries required

Environment

- > Highly effective environmentally sensitive consumable
- > Consumable will not adversely affect drainage pipes, walls or bondings

End customer Satisfaction

- > Avoid malodour, down time and high costs of unblocking drains or even the business being closed down if reported as a statutory nuisance
- > Reduces effluent strength and consequently can reduce disposal costs
- > Creates an improved working environment
- > Attractive, unobtrusive unit design does not disrupt kitchen aesthetics

For more information

www.kennedy-hygiene.co.uk



Kennedy

INTEGRATED HYGIENE SOLUTIONS

GD ULTRA

Compact grease degrader



Packaging info

	Packed	Qty Per	Weight/kg	Measurement in cm
GD ULTRA	Carton	1	1.3	24 x 20 x 17

Technical drawings

Materials: Constructed from engineering thermoplastics. Dispenser can be recycled or disposed of in accordance with local regulations.

Packing: Individual units are packed in a polythene bag and box.

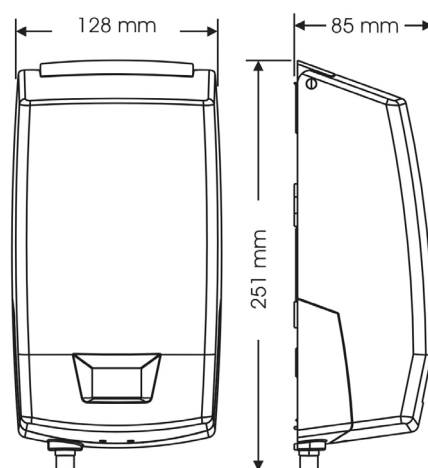

Consumables

> Kennedy's GD Ultra concentrated degreaser solution

Kennedy Hygiene Products Limited

Brookside
Uckfield
East Sussex TN22 1YA
United Kingdom

T +44 (0) 1825 768141
F +44 (0) 1825 768143
E sales@kennedy-hygiene.com

