



Kennedy

WASHROOM HYGIENE SYSTEMS

Kennedy Hygiene Products Limited
Brookside, Uckfield,
East Sussex, TN22 1YA
United Kingdom

Telephone: +44 (0)1825 768141

Fax: +44 (0)1825 768143

E-Mail: sales@kennedy-hygiene.com

Website: www.kennedy-hygiene.com

PRODUCT SPECIFICATION SHEET

TEKNA MECHANICAL RETRACTABLE CABINET

DIMENSIONS

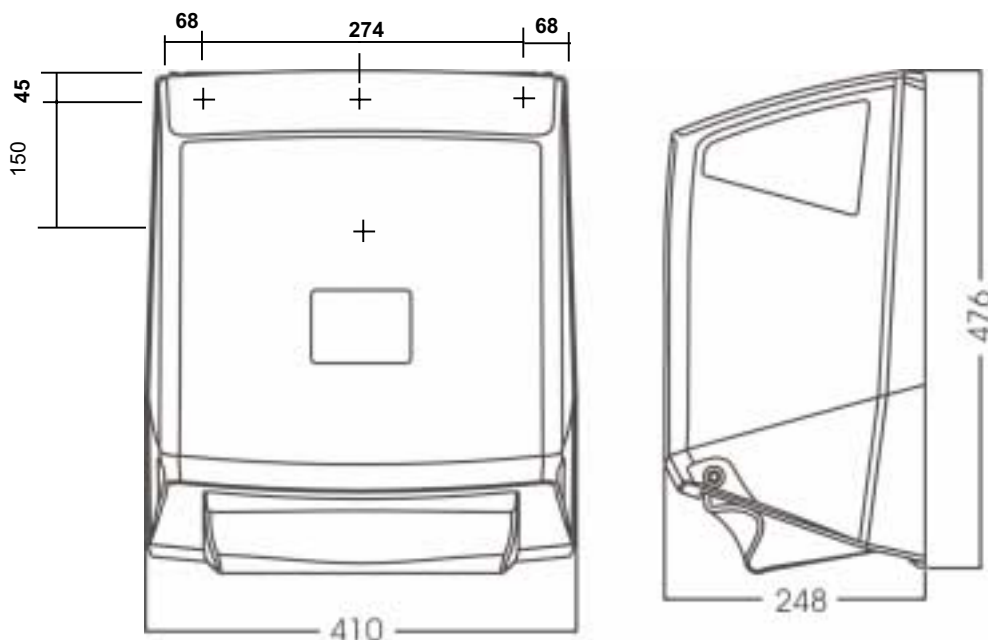

MATERIALS

Constructed from ABS, other engineering thermoplastics and metal fabrication where necessary for strength and reliability. Cabinet can be recycled or disposed of in accordance with local regulations.

PACKAGING

A single cabinet is packed into a double wall box with key and instruction sheet.

Box dimensions: 50cm x 43cm x 26cm

Individual Weight: 8.4kg



EMS 53617



FM 34822