



Kennedy

WASHROOM HYGIENE SYSTEMS

Kennedy Hygiene Products Limited
Brookside, Uckfield,
East Sussex, TN22 1YA
United Kingdom

Telephone: +44 (0)1825 768141

Fax: +44 (0)1825 768143

E-Mail: sales@kennedy-hygiene.com

Website: www.kennedy-hygiene.com

PRODUCT SPECIFICATION SHEET

HOSPITALITY STANDARD CABINET

DIMENSIONS

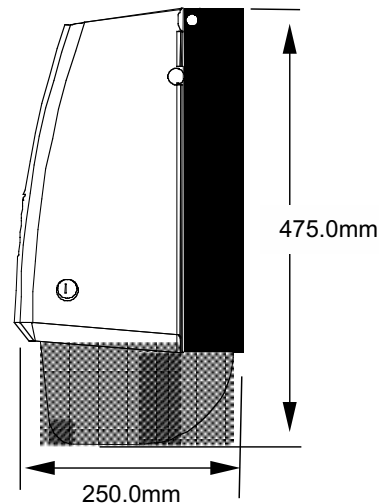
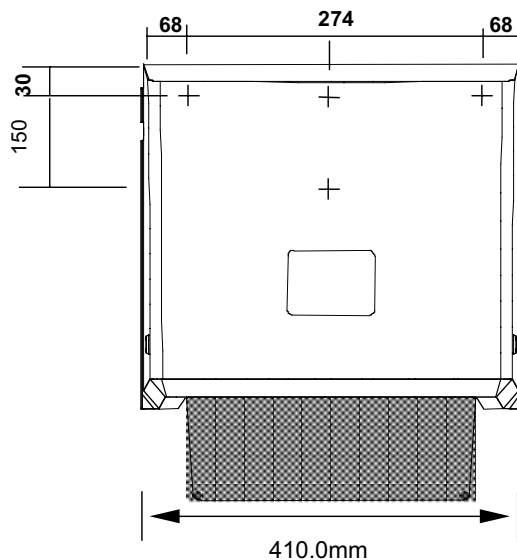

MATERIALS

Backplate made from steel and painted black. Front cover and various internal parts made from ABS and other engineering thermoplastics.

PACKAGING

2 Cabinets are packed into a double wall box with key and instruction sheet.

Box dimensions: 52cm x 41cm x 39cm

Individual Weight: 7kg

Total weight: 16kg



EMS 53617



FM 34822