



**Kennedy**

WASHROOM HYGIENE SYSTEMS

Kennedy Hygiene Products Limited  
Brookside, Uckfield,  
East Sussex, TN22 1YA  
United Kingdom

**Telephone:** +44 (0)1825 768141

**Fax:** +44 (0)1825 768143

**E-Mail:** sales@kennedy-hygiene.com

**Website:** www.kennedy-hygiene.com

## PRODUCT SPECIFICATION SHEET

### LADYSAFE

### DIMENSIONS

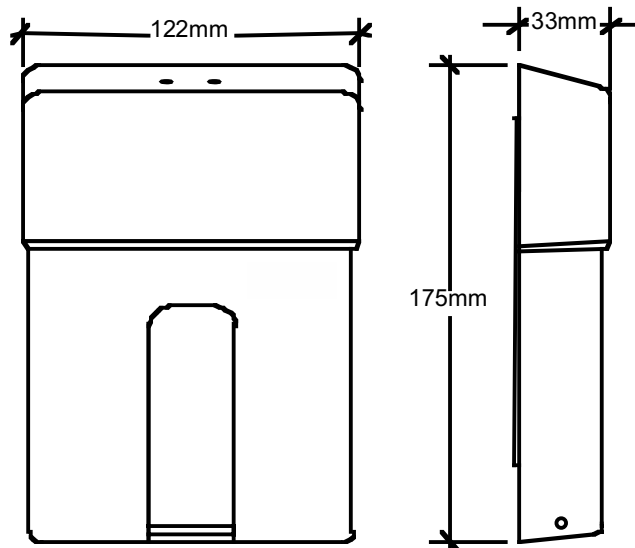

### MATERIALS

Constructed from ABS. Dispenser can be recycled or disposed of in accordance with local regulations.

### PACKING

Individual Ladysafes are packed in polybag with 2 keys and fitted into protective card sleeve.

Individual weight: 242g

36 Ladysafes packed in carton: 390mm x 370mm x 250mm

Total weight: 11.0kg



EMS 53617



FM 34822