

**PRODUCT SPECIFICATION SHEET**

**INTIMA MINI**

**KHP Part No: Manual: LAD BIN IMI UNP**  
**Foot Pedal: LAD BIN IMI PDL UNP**  
**Auto: LAD BIN IMI AUT UNP**

**DESCRIPTION**

- 15 Litre bin capacity
- Available in foot pedal, manual and electronic no-touch models
- Reversible top cover for easy location either side of the cubicle
- Designed with soft edges to aid cleaning
- Top cover easily/quickly removed for speedy service
- Discreet recess in back of the cover to ease carrying

**DIMENSIONS**

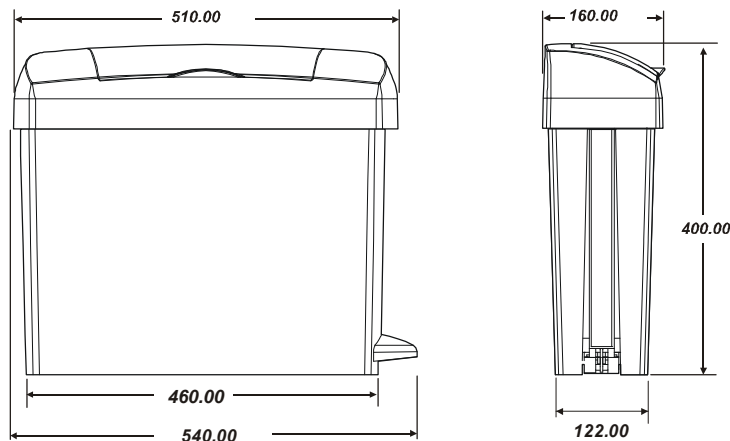

**MATERIALS**

Constructed predominantly from ABS.  
 Dispenser can be recycled or disposed of in accordance with local regulations.

**PACKING**

Assembled units packed in poly bags, two in a carton.  
 Individual weight:      Manual - 2.2kg      Total weight:      Manual - 4.9kg  
                                  Pedal - 2.4kg                              Pedal - 5.3kg  
                                  Auto - 2.6kg                              Auto - 5.7kg