



Kennedy

WASHROOM HYGIENE SYSTEMS

Kennedy Hygiene Products Limited
Brookside, Uckfield,
East Sussex, TN22 1YA
United Kingdom
Telephone: +44 (0)1825 768141
Fax: +44 (0)1825 768143
email: sales@kennedy-hygiene.com
Website: www.kennedy-hygiene.com

PRODUCT SPECIFICATION SHEET

INTIMA

KHP Part No: Manual: LAD BIN ITM UNP
Foot Pedal: LAD BIN ITM PDL UNP
Auto: LAD BIN ITM AUT UNP

DESCRIPTION

- 23L bin capacity
- Available in foot pedal, manual and electronic no-touch models
- Reversible top cover for easy location either side of the cubicle
- Designed with soft edges to aid cleaning
- Top cover easily/quickly removed for speedy service
- Discreet recess in back of the cover to ease carrying

DIMENSIONS

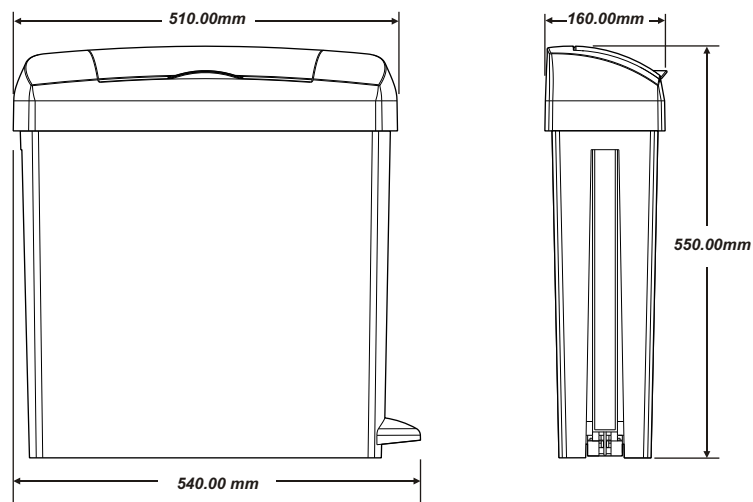

MATERIALS

Constructed predominantly from ABS.
Dispenser can be recycled or disposed of in accordance with local regulations.

PACKING

Assembled units packed in poly bags, two in a carton.
Individual weight: 3kgs
Total weight: 6.5kgs approximately

PSS (Intima) OCT 2004



EMS 53617



FM 34822